

**Technical Database  
&  
Outline Specification**

(Section headings only as the contents contain commercially valuable secrets)

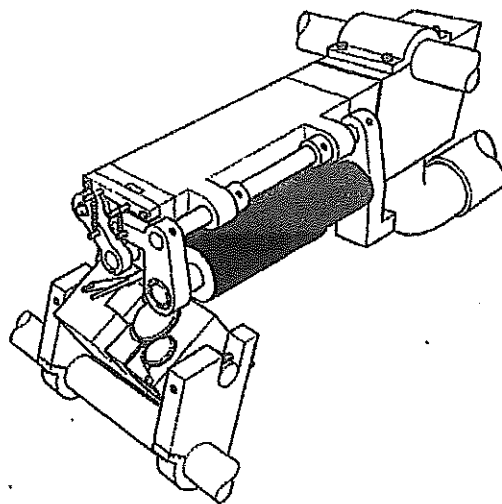

2.           GENERAL BACKGROUND TO FRICTION SPINNING
  
3.           POST SPINNING PROCESS
  - 3.1.        YARN SUPPLIED TO DIFFERENT SECTORS
  - 3.2.        YARN FEATURES
  - 3.3.        PACKAGE REQUIREMENTS
  - 3.4.        CONTINUALLY CHANGING REQUIREMENTS
  
4.           DESIGN CONCEPT OF A NEW SPINNING MACHINE
  
5.           BASIC PRINCIPLES OF OUR PROPOSED FRICTION SPINNING SYSTEM
  - 5.1.        PROVIDING A "NIP-POINT"
  - 5.2.        INDIVIDUAL FIBRE DRAW OUT
  - 5.3.        SPEED OF FIBRES
  - 5.4.        FIBRE DRAW-OFF
  - 5.5.        AIR SUCTION
  - 5.6.        PERFORATED AND SOLID ROLLERS
  - 5.7.        TRANSFER TUBE
  - 5.8.        FORMATION OF YARN
  - 5.9.        RELATIONSHIP BETWEEN COMPONENTS
  
6.           YARN DEFINITION
  - 6.1.        FRICTION SPUN OPEN END YARNS
  - 6.2.        FUTURE DEFINITIONS
  - 6.3.        YARN DEFINITION PRIOR TO FRICTION SPINNING
  - 6.4.        NON "OPEN-END" FRICTION YARNS
  - 6.5.        CHANGES IN YARN PROPERTIES
  
7.           YARN STRUCTURE
  - 7.1.        THE DEGREE OF PARALLELISATION OF THE FIBRES WITHIN THE YARN
  - 7.2.        THE LENGTH OF THE TIP OF THE YARN
    - 7.2.1.      Length too short
    - 7.2.2.      Length too long
  - 7.3.        YARN TWIST
    - 7.3.1.      Twist measurement
    - 7.3.2.      No fibre migration
    - 7.3.3.      No wrapper fibre
    - 7.3.4.      Proof by experiments
  
8.           YARN PROPERTIES
  - 8.1.        STRENGTH
    - 8.1.1.      Relationship between strength and twist
      - 8.1.1.1.     100% Cotton
      - 8.1.1.2.     100% Polyester, 100% Acrylic or blends of these
      - 8.1.1.3.     Blends of acrylic/polyester with cotton

## SECTION

9. COMPARISON WITH RING AND ROTOR SPINNING
  - 9.1. STRENGTH DIFFERENCES
    - 9.1.1. Comparison with rotor spinning
    - 9.1.2. Comparison with ring spinning
  - 9.2. CORRECT FABRIC HANDLE
  - 9.3. REGULARITY
  - 9.4. TWIST
    - 9.4.1. Range of twist levels
    - 9.4.2. Twist and strength
    - 9.4.3. Factors which affect twist
    - 9.4.4. Individual fibre twist
    - 9.4.5. Selection of twist level
      - 9.4.5.1. Cut pile fabrics
      - 9.4.5.2. Raised fabrics
      - 9.4.5.3. Knitted and woven fabrics
    - 9.4.6. Yarn faults
    - 9.4.7. Processing of friction spun yarns
  
10. DRAWBACKS OF MACHINE CURRENTLY AVAILABLE
  - 10.1. PATENTS IN FORCE
  - 10.2. TECHNOLOGY NOT UP TO DATE
  - 10.3. PLATT SACO LOWELL (UK) LTD.
  - 10.4. THE P.S.L. MASTERSPINNER
  - 10.5. RELEASED ON TO THE MARKET TOO SOON
  
11. A NEW FRICTION SPINNING UNIT
  - 11.1. OVERCOMING PATENT COVERAGE
  - 11.2. VISIBLY DIFFERENT
  - 11.3. CURRENT OPERATIONAL DIFFICULTIES OVERCOME
  - 11.4. CONCENTRATED DESIGN EFFORT
  - 11.5. INDIVIDUAL COMPONENT AREAS
  
12. BEATER OPENING SECTION
  - 12.1. SLIVER CONTROL
  - 12.2. FIBRE TAKE-OFF
  - 12.3. EFFECT ON MACHINE DESIGN
  
13. TRANSFER TUBE
  - 13.1. OPTIMUM ANGLE AND DIRECTION OF FIBRE FEED
    - 13.1.1. Basic DREF system
    - 13.1.2. Feeding fibres at an angle
    - 13.1.3. Changes to transfer tube
    - 13.1.4. Feeding in a rearward direction
    - 13.1.5. Feeding in a forward direction
  - 13.2. TECHNOLOGICAL DIFFERENCES BETWEEN FEED DIRECTIONS
    - 13.2.1. Formation of a friction spun yarn
    - 13.2.2. Fibre contact point
    - 13.2.3. Leading and trailing fibre ends
    - 13.2.4. Fibre doubling with friction spinning
      - 13.2.4.1. Position of the fibres on the beater
      - 13.2.4.2. Fibres fed at right angles to yarn axis
      - 13.2.4.3. Fibres fed to the yarn axis at other angles
      - 13.2.4.4. Length of fibre travel affects their velocity

## SECTION

- 13.2.4.5.           Significance relative to rearward feed
- 13.2.4.6.           Significance relative to forward feed
- 13.2.4.7.           Doubling better with rearward feed
- 13.2.4.8.           Effect of sliver irregularity on yarn
- 13.2.5.            Prevention of one fibre type becoming prevalent
- 13.2.6.            Fibre contraction during rearward feed
  - 13.2.6.1.           Theoretical contraction rate
  - 13.2.6.2.           Forces affecting contraction rate
- 13.2.7.            Fibre alignment throughout yarn structure
  - 13.2.7.1.           Rearwards feed
  - 13.2.7.2.           Forwards feed
  - 13.2.7.3.           Expected differences in yarn properties
- 13.3.            TRANSFER TUBE SPECIFICATION
  - 13.3.1.            Transfer tube design affects optimisation of air flows
  - 13.3.2.            Optimisation other than by a secondary suction force
  - 13.3.3.            Dimensions at fibre take-off point
  - 13.3.4.            Inlet angle relative to friction rollers
  - 13.3.5.            Dimensions at friction roller end
  - 13.3.6.            Outlet angle must vary relative to friction rollers
  - 13.3.7.            Cross section shape
  - 13.3.8.            Overcoming fibre trapping problem
  - 13.3.9.            Improvements which also overcome patent coverage
  
- 14.            THE TWO FRICTION ROLLERS
  - 14.1.            BOTH ROLLERS PERFORATED
  - 14.2.            ONLY ONE OF THE TWO ROLLERS PERFORATED
  
- 15.            ROLLER PARAMETERS WITH ONLY ONE ROLLER PERFORATED
  - 15.1.            PRESENT PERFORATED ROLLER
    - 15.1.1.            Texturing discs
    - 15.1.2.            Perforated roller coating
  - 15.2.            SOLID (FRICTION) ROLLER
    - 15.2.1.            Same coating as perforated roller
    - 15.2.2.            Aluminium vacu-blasted roller
    - 15.2.3.            Fluting
    - 15.2.4.            Knurling
    - 15.2.5.            Match vacu-blasted aluminium
    - 15.2.6.            Chrome plating
    - 15.2.7.            Nickel plating
    - 15.2.8.            Anodising
    - 15.2.9.            Find alternative
      - 15.2.9.1.           Development programme
      - 15.2.9.2.           Roughness requirement
      - 15.2.9.3.           Not commercially available with plasma spraying
      - 15.2.9.4.           D. Gun process
      - 15.2.9.5.           Results achieved with D. Gun process
      - 15.2.9.6.           New plasma spray process
      - 15.2.9.7.           Advances in spray technology still being made
  - 15.3.            PLASMA SPRAY SUITABILITY
    - 15.3.1.            Commercial viability
    - 15.3.2.            Post coating treatment
  - 15.4.            ROLLER ROUGHNESS
    - 15.4.1.            Roller roughness measurement and twist not related

## SECTION

- 15.4.2. Specialist research establishments
- 15.4.3. Wrong problem addressed
- 15.5. VARIATION OF TWIST
- 15.6. PLASMA SPRAY IMPROVEMENTS
- 15.7. INCONSISTENCY OF FRICTION ROLLER SURFACES
- 15.8. COATING OF PERFORATED ROLLER
  - 15.8.1. Special cooling
  - 15.8.2. Thickness of plasma coating
  - 15.8.3. Effect of thickness variation
- 15.9. BLEMISHES TO SURFACE COATING
- 15.10. TWIST EFFICIENCY
  - 15.10.1. Complex relationship
  - 15.10.2. Definition
  - 15.10.3. Example
  - 15.10.4. Reduces with twist
  - 15.10.5. Affected by yarn count
  - 15.10.6. Affected by fibre type
    - 15.10.6.1. Results at identical conditions
    - 15.10.6.2. Typical figures for twist efficiency
    - 15.10.6.3. No correlation
  - 15.10.7. Spinning tension
  - 15.10.8. Spinning performance
    - 15.10.8.1. Twist efficiency too high
    - 15.10.8.2. Twist efficiency too low
    - 15.10.8.3. Acceptable level of twist efficiency
  - 15.10.9. Yarn properties
    - 15.10.9.1. High twist efficiency
    - 15.10.9.2. Low twist efficiency
- 15.11. PRIOR ART
- 15.12. INCREASING TWIST EFFICIENCY
  - 15.12.1. Implication of twist efficiency fall off with speed
  - 15.12.2. Practical effect
  - 15.12.3. Our proposals
    - 15.12.3.1. Target twist efficiency
    - 15.12.3.2. Example
    - 15.12.3.3. Effect on installed power
    - 15.12.3.4. Alternative systems
    - 15.12.3.5. Practical experience
    - 15.12.3.6. Patents
- 16. METHOD OF ROLLER PERFORATION
  - 16.1. MECHANICAL DRILLING
    - 16.1.1. Specialist drilling Companies
    - 16.1.2. Specialist drilling machine
    - 16.1.3. Wall thickness
    - 16.1.4. Selection of roller material
    - 16.1.5. Drilling time
  - 16.2. LASER DRILLING
  - 16.3. SINTERED FILTER
  - 16.4. FOIL PRODUCTION
  - 16.5. ELECTRON BEAM DRILLING
  - 16.6. CONCLUSION

SECTION

- 17. PERFORATION SPECIFICATION
  - 17.1. DIAMETER AND SPACING OF HOLES
  - 17.2. EFFECT OF COATING
  - 17.3. EFFECT OF HOLE DIAMETER TOO LARGE
  - 17.4. EFFECT OF HOLE DIAMETER TOO SMALL
  - 17.5. POST DRILLING TREATMENT
  
- 18. OUTLINE SPECIFICATION OF NEW PERFORATED ROLLER
  
- 19. FUNCTIONS OF SLOTTED SLEEVE INSIDE PERFORATED ROLLER
  - 19.1. CORRECT YARN POSITION
  - 19.2. DRAWING FIBRES FROM THE BEATER
  
- 20. POINT OF REFERENCE FOR SLOT POSITION
  
- 21. SLOT WIDTH EXPERIMENTS WITH TWO PERFORATED ROLLERS
  - 21.1. SLOT WIDTH VARIATIONS
  - 21.2. AIR LEAKAGES
  - 21.3. EXPERIMENTS STOPPED
  
- 22. DEVELOPMENT SWITCHED TO ONE PERFORATED ROLLER
  - 22.1. AIR AVAILABLE REDUCED
  - 22.2. PREVENTION OF BEATER LOADING
  
- 23. STAGE ONE EXPERIMENTS ON SLOT PARAMETERS
  
- 24. RESULTS OF STAGE ONE EXPERIMENTS ON SLOT PARAMETERS
  - 24.1. EFFECT OF SLOT POSITION ON TWIST EFFICIENCY
  - 24.2. EFFECT OF SLOT WIDTH ON YARN PROPERTIES
    - 24.2.1. Narrower the slot then greater the twist efficincy
    - 24.2.2. Narrower the slot then stronger the yarn
  - 24.3. EFFECT OF SLOT WIDTH ON AIR USAGE
    - 24.3.1. Determination of air usage
    - 24.3.2. Narrower the slot then less air usage
  
- 25. CONCLUSIONS FROM STAGE ONE EXPERIMENTS ON SLOT PARAMETERS
  - 25.1. PRELIMINARY CHOICE OF SLOT POSITION AND WIDTH
  - 25.2. OPTIMUM LEVELS ACHIEVED NOT CONCLUSIVE
  
- 26. STAGE TWO EXPERIMENTS ON SLOT PARAMETERS
  - 26.1. SLOT WIDTH
  - 26.2. SLOT SHAPE
  - 26.3. SLOT POSITION

SECTION

27. SLOT POSITION ADJUSTER

28. EXPERIMENTS TO JUSTIFY SLOT POSITION ADJUSTER

28.1. EFFECT OF SLOT POSITION ON YARN PROPERTIES

28.1.1. Experiments with ten spinning units

28.1.1.1. Nine different slot positions

28.1.1.2. Adjustment to friction rollers

28.1.1.3. Yarn strength varied

28.1.2. Experiments on full length machines

28.1.2.1. Yarn strength comparisons

28.1.2.2. Slot positions

28.1.2.3. Yarn strength allied to slot position

28.1.2.4. Statistical analysis

28.1.2.5. Variance with previous results

29. SETTING SLOTTED SLEEVE RELATIVE TO PERFORATED ROLLER

29.1. SLOT LENGTH POSITION

29.2. INTERNAL SETTING OF SLOT

29.2.1. Reducing air losses

29.2.2. Piecing method influences ability to set slot accurately

30. EFFECT OF GAP BETWEEN SLEEVE AND ROLLER VARYING IN SIZE

30.1. BEATER LOADING

30.2. YARN PROPERTIES

30.2.1. Twist level

30.2.1.1. Suction force

30.2.1.2. Equivalent slot width

30.2.1.3. Air flow pattern

30.2.2. Strength

30.2.3. Spinning performance

30.3. POSITION TO POSITION VARIATION

31. EFFECT OF STATIC PRESSURE ON YARN PROPERTIES

31.1. UNIT ASSEMBLED DETERMINES AIR FLOW

31.2. STATIC PRESSURE TOO LOW

31.3. EFFECT OF STATIC PRESSURE ON TWIST

31.3.1. Relationship depends on fibre type and count

31.3.2. Effect of delivery speed

31.3.3. No pattern as to relative effect

31.4. EFFECT OF STATIC PRESSURE ON STRENGTH

31.4.1. Yarns never weaker

31.4.2. Relationship with fibre type and count

31.4.3. Effect of delivery speed

31.4.4. Strength/twist

31.5. EFFECT OF STATIC PRESSURE ON REGULARITY

31.6. EFFECT OF STATIC PRESSURE ON HAIRINESS

31.7. EFFECT OF STATIC PRESSURE ON SPINNING PERFORMANCE

## SECTION

- 31.7.1. Incidence of end breaks
- 31.7.2. Relationship with fibre type and count
- 31.8. EFFECT OF STATIC PRESSURE ON THIN PLACES

## 32. BAFFLE IN SLOTTED SLEEVE

- 32.1. EARLY EXPERIMENTS
- 32.2. SPINNING PERFORMANCE NON COMMERCIAL
- 32.3. DEFINITION OF BAFFLE
- 32.4. COVERED IN PATENTS
- 32.5. BAFFLE MAKES SPINNING PERFORMANCE COMMERCIAL
- 32.6. IMPROVEMENT EVIDENT ON ALL YARNS
- 32.7. EFFECT OF BAFFLE ON YARN STRENGTH
- 32.8. FUTURE DEVELOPMENTS
- 32.9. EFFECT OF BAFFLE ON TWIST
- 32.10. EFFECT OF BAFFLE ON REGULARITY
- 32.11. EFFECT OF BAFFLE ON THIN PLACES
  - 32.11.1. Uster
  - 32.11.2. Classimat
- 32.12. OPERATIONAL DIFFICULTIES
  - 32.12.1. Design considerations
  - 32.12.2. Problem created

## 33. PROPOSED NEW DESIGN OF SLOTTED SLEEVE

- 33.1. BACKGROUND
- 33.2. MAIN FEATURES
  - 33.2.1. Slot width
  - 33.2.2. Slot length
  - 33.2.3. Piecing method
  - 33.2.4. Mounting of perforated roller
  - 33.2.5. Non circular slotted sleeve
  - 33.2.6. Reasons for non circular shape
- 33.3. VARIANTS
  - 33.3.1. Preventing patent infringement
  - 33.3.2. Slotted sleeve design
    - 33.3.2.1. Depth of slot
    - 33.3.2.2. Proposed slot details
  - 33.3.3. Advantages of proposed design
    - 33.3.3.1. Air flow
    - 33.3.3.2. Problem of blocking eliminated
    - 33.3.3.3. Definition of proposed new system
  - 33.3.4. Development work

## 34. DEFINITION OF NEW PERFORATED ROLLER ASSEMBLY

## 35. GAP BETWEEN ROLLERS

- 35.1. DEFINITION
- 35.2. FACTORS AFFECTING ROLLER GAP
  - 35.2.1. Eccentricity of friction spinning rollers
  - 35.2.2. Diameter variations along roller length

## SECTION

- 35.2.3. Clearance in bearings
- 35.2.4. Mounting of rollers
- 35.2.5. Operating temperature
- 35.3. STANDARDS REQUIRED
- 35.3.1. Maximum variation in gap
- 35.3.2. Position to position uniformity
- 35.3.3. Effect of eccentricity on yarn properties
- 35.3.3.1. Strength
- 35.3.3.2. Yarn regularity
- 35.3.3.3. Spinning performance
- 35.3.4. Effect of gap variations along roller length
- 35.4. EFFECT OF GAP SETTING ON TWIST
- 35.4.1. What we mean by gap setting
- 35.4.2. Closer the gap greater the twist
- 35.5. GAP SETTING TOO CLOSE
- 35.5.1. Count range 10 Nec. to 30 Nec.
- 35.5.2. Counts finer than 30 Nec.
- 35.6. GAP SETTING TOO WIDE
- 35.6.1. Yarn strength
- 35.6.2. Spinning performance
- 35.6.2.1. Fine yarns
- 35.6.2.2. Coarse yarns
- 35.6.3. Regularity
- 35.7. SELECTION OF CORRECT GAP
- 35.7.1. Gap for coarse yarns
- 35.7.2. Gap for fine yarns
- 35.7.3. Conclusion
  
- 36. TRANSFER TUBE SETTINGS
- 36.1. GENERAL
- 36.2. POSITION OF INLET SLOT
- 36.3. POSITION OF EXIT SLOT
- 36.4. FIBRE FLOW PATH
- 36.4.1. All units to have identical paths
- 36.4.2. Effect of non-identical paths
- 36.5. POSITION RELATIVE TO PERFORATED ROLLER
- 36.5.1. Reducing air losses
- 36.5.2. Prototype unit
- 36.5.3. First production unit design
- 36.5.4. Modifications to this design
- 36.5.5. New design
- 36.6. POSITION RELATIVE TO SOLID ROLLER
- 36.6.1. Reducing air losses
- 36.6.2. Prototype unit
- 36.6.3. First production unit design
- 36.6.4. Modification to this design
- 36.6.5. Spinning performance
- 36.6.5.1. A method to improve spinning performance
- 36.6.5.2. No improvement to already satisfactory units
- 36.6.5.3. Action taken
- 36.6.6. Effect of setting on yarn twist

## SECTION

- 36.6.7. Non parallel gap
- 36.6.7.1. Results
- 36.6.7.2. Results unexpected
- 36.6.7.3. Setting to perforated roller constant
- 36.6.7.4. Setting to beater housing
- 36.6.8. Conclusions
- 36.6.8.1. Need for consistency
- 36.6.8.2. Optimum setting
- 36.6.8.3. Other yarn properties

## 37. TWIST VARIATION BETWEEN UNITS

- 37.1. BACKGROUND
- 37.2. INTERACTIONS BETWEEN FEATURES
- 37.3. QUALITY CONTROL AND ACCEPTANCE LIMITS
- 37.3.1. Commercial decision
- 37.3.2. Special friction spinning requirements
- 37.3.2.1. No absolute standard of twist
- 37.3.2.2. Standards must be created
- 37.3.2.3. Ensures compatability of units
- 37.3.2.4. Precautions needed
- 37.4. STANDARDS ACHIEVED ON EXISTING COMMERCIAL MACHINES
- 37.4.1. Existing procedures
- 37.4.1.1. Selection of material
- 37.4.1.2. Standards at first spin
- 37.4.1.3. Re-working units
- 37.4.1.4. Acceptance standards
- 37.4.2. Reject rate
- 37.4.3. Testing error
- 37.4.3.1. Twist test procedure
- 37.4.3.2. To determine true twist of a unit
- 37.4.3.3. Difference between measured and true twist
- 37.4.3.4. Range of true twist levels
- 37.4.4. Mill results
- 37.4.4.1. Fresh set of operating conditions
- 37.4.4.2. All units to be checked for twist
- 37.4.4.3. Some units do not reach standards
- 37.4.4.4. Subsequent fibre and/or yarn count changes
- 37.4.4.5. Frequency of change of product
- 37.5. EFFECT OF REDUCING VARIABILITY OF FACTORS AFFECTING TWIST
- 37.5.1. 50% reduction
- 37.5.2. 75% reduction
- 37.6. NEW DESIGN PROPOSALS
- 37.6.1. Detailed knowledge improves design
- 37.6.2. Great emphasis on design and tolerances set
- 37.6.3. Need to invest in plant and quality control
- 37.6.4. How to achieve improvements

## 38. PIECING METHOD

- 38.1. BACKGROUND
- 38.1.1. Commercial requirements
- 38.1.2. In early stages not possible to piece up
- 38.1.3. Development of piecing method
- 38.1.4. Details of present system
- 38.1.5. DREF system

## SECTION

- 38.2. DISADVANTAGES OF COMMERCIALY AVAILABLE SYSTEMS
  - 38.2.1. Dref system
  - 38.2.2. P.S.L. system
    - 38.2.2.1. Complicates spinning unit
    - 38.2.2.2. Suction must be blocked off
    - 38.2.2.3. Slub removal
    - 38.2.2.4. Risk of fire
    - 38.2.2.5. Running non operational units
    - 38.2.2.6. Electrical complications
    - 38.2.2.7. Depends on operator skill
- 38.3. PRESENT PATENT SITUATION
  - 38.3.1. Validity of patents
  - 38.3.2. Continually under review
- 38.4. PRINCIPLES OF OPERATION OF PROPOSED NEW DESIGN
  - 38.4.1. At spinning break
  - 38.4.2. To re-start spinning
- 38.5. DESIGN FEATURES
  - 38.5.1. Switching perforated roller suction on and off
    - 38.5.1.1. Remote from spinning unit
    - 38.5.1.2. Simplified spinning unit design
    - 38.5.1.3. Method of switching on and off
  - 38.5.2. Switching yarn entrainment nozzle on and off
    - 38.5.2.1. Remote from spinning unit
    - 38.5.2.2. Method of switching on and off
    - 38.5.2.3. Quantity of air
  - 38.5.3. Both suction ducts open at same time
  - 38.5.4. Stopping and starting fibre feed
  - 38.5.5. Package lift at spinning break
  - 38.5.6. Air jet switched on and off
  - 38.5.7. Doffing tube
    - 38.5.7.1. Positioning
    - 38.5.7.2. Aligning hole in doffing tube
    - 38.5.7.3. Reasons
  - 38.5.8. Electrical
    - 38.5.8.1. At spinning break
    - 38.5.8.2. To re-start spinning
- 39. PIECING QUALITY
  - 39.1. CAN MEET STANDARDS SET FOR ROTOR YARNS
  - 39.2. APPEARANCE IN FABRIC
  - 39.3. PIECING STRENGTH
  - 39.4. ELECTRONIC PIECING TESTER ON FRICTION YARN
    - 39.4.1. Principles of piecing
    - 39.4.2. Thin places break on rotor spinning
    - 39.4.3. Thin places do not break on friction spinning
    - 39.4.4. Level of thick place
  - 39.5. EXPERIMENTAL RESULTS
    - 39.5.1. Tests carried out
    - 39.5.2. Results
  - 39.6. ADVANTAGES WITH PROPOSED NEW DESIGN
    - 39.6.1. Reproducible piecings
    - 39.6.2. Less prone to produce poor piecings
    - 39.6.3. Suction switching remote from spinning unit
      - 39.6.3.1. Does not compromise any future advances
      - 39.6.3.2. Simple electrical plug

## SECTION

- 39.6.4.           Suction switched off at end break
- 39.6.4.1.        Residual fibre cleared
- 39.6.4.2.        No fire risk
- 39.6.4.3.        No roller contamination
- 39.6.4.4.        Spinning unit does not require opening
- 39.6.5.           Stop/Start
- 39.6.5.1.        Required on rotor spinning machines
- 39.6.5.2.        Experiments on friction spinning

## 40.           YARN SPLICING

- 40.1.            RING SPUN SPLICINGS
- 40.2.            ROTOR AND JET SPUN SPLICINGS
- 40.3.            FRICITION SPUN SPLICINGS
- 40.3.1.          Experiments
- 40.3.2.          Commercial splicers
- 40.3.3.          Spliced friction yarn in commercial use

## 41.            AUTOMATIC PIECING

- 41.1.            ROTOR SPINNING
- 41.2.            SAME FEATURES SHOULD BE AVAILABLE ON  
FRICITION SPINNING
- 41.3.            OPTIONS AVAILABLE
- 41.3.1.          Requirements for piecings
- 41.3.2.          Automating on existing manual system
- 41.3.3.          Robatic control of spinning functions
- 41.3.4.          Piecing at low delivery speed
- 41.3.4.1.        No advantage
- 41.3.4.2.        Maintaining compatible yarn during acceleration
- 41.4.            NEW DESIGN PROPOSALS
- 41.4.1.          Factors already discussed in report
- 41.4.2.          Actions required of robot
- 41.4.3.          Development effort required
- 41.4.3.1.        Requirement already for rotor spinning
- 41.4.3.2.        Thread path changes from rotor to friction
- 41.4.3.3.        Simple tasks for robot
- 41.4.4.          Alternative system
- 41.4.5.          Overall concept of automation

## 42.            COMPARISON OF FRICTION SPUN SPLICINGS WITH AUTOMATIC ROTOR SPUN PIECINGS

- 42.1.            DETAILS OF COMPARISONS
- 42.2.            RESULTS
- 42.2.1.          Test size
- 42.2.2.          Conclusions

## 43.            AUTOMATIC PIECING WITH SPLICING

- 43.1.            PIECING OR SPLICING ?
- 43.2.            SPLICING COMMERCIALLY ACCEPTABLE
- 43.3.            BEST FRICTION PIECINGS ACHIEVED TO DATE
- 43.4.            SPLICING ON A FRICTION SPINNING MACHINE
- 43.4.1.          Major problem to overcome
- 43.4.2.          Commercial systems

## SECTION

- 43.4.2.1. Schubert and Saltzer rotorspinner
- 43.4.2.2. Murata jet spinner
- 43.4.3. Options
- 43.4.4. Recommendations
- 43.4.4.1. Splicing must be available
- 43.4.4.2. Choice of option
  
- 44. AUTOMATIC DOFFING
  
- 45. AUTOMATIC DOFFING AND PIECING
- 45.1. BACKGROUND
- 45.2. COMMERCIAL SYSTEMS AVAILABLE
- 45.3. SELECTION OF SYSTEM FOR FRICTION SPINNING
  
- 46. AIR FLOW ANALYSIS
- 46.1. POWER COSTS MUST BE COMPETITIVE
- 46.2. PITFALLS IN MEASURING AIRFLOW
- 46.3. AIRFLOW PATH THROUGH SPINNING UNIT
- 46.3.1. Inside the perforated roller
- 46.3.2. Air intended for transfer tube
- 46.3.3. Air drawing round beater
- 46.4. AIR DRAWN INSIDE PERFORATED ROLLER
- 46.4.1. Background
- 46.4.2. Assumptions made
- 46.4.3. Examples
- 46.4.3.1. Single perforated roller with 3mm. wide slot
- 46.4.3.2. Two perforated rollers each with a 3mm. wide slot
- 46.4.3.3. Single perforated roller with a 5mm. wide slot
- 46.4.3.4. Two perforated rollers with reduced perforated area
- 46.4.4. Frictional air losses
- 46.4.4.1. A narrow slot restricts air
- 46.4.4.2. Examples
- 46.5. AIR DRAWN THROUGH PERFORATED ROLLER
- 46.5.1. Background
- 46.5.2. Assumptions made
- 46.5.3. Examples
- 46.6. AIR DRAWN OFF BEATER
- 46.7. ACTUAL RESULTS
- 46.7.1. Background
- 46.7.2. Gap between transfer tube and friction spinning rollers
- 46.7.2.1. Effect on air flow
- 46.7.2.2. Air drawn down doffing tube
- 46.7.2.3. Eliminating beater loading
- 46.7.3. Position of slot in slotted sleeve
- 46.7.4. Friction spinning rollers running
- 46.7.5. Processing material
- 46.7.6. Air flow on baffled spinning unit
- 46.8. SUMMARY
- 46.8.1. Air drawn through perforated roller
- 46.8.2. Air drawn down transfer tube

## SECTION

- 46.9. UNEXPLAINED EVENTS
  - 46.9.1. Background
  - 46.9.2. Pressure drop in yarn formation zone
  - 46.9.3. Baffle spinning unit
    - 46.9.3.1. Theoretical disagrees with actual results
    - 46.9.3.2. Perforated roller acts as restrictor
    - 46.9.3.3. Friction losses due to perforations
    - 46.9.3.4. Pressure drop along slotted sleeve
    - 46.9.3.5. Combination of effects
  - 46.9.4. Gap between solid roller and transfer tube
    - 46.9.4.1. Insignificant reduction in air flow
    - 46.9.4.2. Explanation
  - 46.9.5. Alternative to single 3mm. wide slot
    - 46.9.5.1. Background
    - 46.9.5.2. Two perforated rollers each with 3mm. wide slot
    - 46.9.5.3. One perforated roller with a 5mm. wide slot
- 46.10. TO MAKE A TWO PERFORATED ROLLER SYSTEM  
POWER COMPETITIVE
  - 46.10.1. Background
  - 46.10.2. To achieve competitive power consumption
    - 46.10.2.1. Introduction
    - 46.10.2.2. Reducing area of perforated roller covered in holes
    - 46.10.2.3. Leakages
  - 46.10.3. Yarn properties
  - 46.10.4. Engineering changes
    - 46.10.4.1. Perforated rollers
    - 46.10.4.2. Slotted sleeve
    - 46.10.4.3. Method of support
    - 46.10.4.4. Air switching
    - 46.10.4.5. Setting gap between rollers
    - 46.10.4.6. Power increases
  - 46.10.5. Advantages
  - 46.10.6. Fly and dust problems
- 47. SPINNING AIR REQUIRED FOR FULL LENGTH MACHINE
  - 47.1. AIR USAGE PER POSITION
  - 47.2. REQUIREMENTS FOR FULL MACHINE
    - 47.2.1. Small pressure drop along machine
    - 47.2.2. Number of positions on machine
    - 47.2.3. Duct size
- 48. SELECTION OF FAN SYSTEM
  - 48.1. DISCUSSIONS WITH SUPPLIER
  - 48.2. INFORMATION TO BE PROVIDED
    - 48.2.1. Fan capability
    - 48.2.2. Handling dust
    - 48.2.3. Maintaining static pressure
    - 48.2.4. Air conditioning plant
- 49. TRASH REMOVAL

## SECTION

- 50. OPERATIONAL DIFFICULTIES ON EXISTING MACHINES
- 50.1. GREASE ESCAPING FROM BEARINGS
- 50.1.1. Reasons for escape of grease
- 50.1.2. Problems created
- 50.1.3. Partial solution found
- 50.1.4. Proposed new design
- 50.1.4.1. Many of existing problems caused by piecing method
- 50.1.4.2. Alignment improved
- 50.1.4.3. Eliminating air drawn through bearings
- 50.1.4.4. Seals can be fitted
- 50.2. TANGENTIAL BELT DRIVE
- 50.2.1. Problems on existing system
- 50.2.2. Action being taken to reduce problem
- 50.2.3. Only 72 units per side
- 50.2.4. Our proposed new design
- 50.2.4.1. Indirect drive
- 50.2.4.2. Auxiliary drive roller
- 50.3. PROBLEMS ASSOCIATED WITH FLY AND DUST
- 50.3.1. Fibre and dust attached to perforated roller
- 50.3.1.1. Fibres released attaches to ledges etc.
- 50.3.1.2. Clumps are released
- 50.3.1.3. Low % released
- 50.3.2. Methods employed to overcome problem
- 50.3.2.1. A number of companies encountered problem
- 50.3.2.2. Scraper blades
- 50.3.2.3. Shroud
- 50.3.2.4. Partial shroud and suction slot
- 50.3.2.5. Pressurisation
- 50.3.3. External fly and dust
- 50.3.3.1. Air drawn through perforated rollers
- 50.3.3.2. Fibre forming on outside of machine
- 50.3.3.3. Travelling cleaner
- 50.3.3.4. External factors
- 50.3.4. Surfaces should not attract fly and dust
- 50.3.5. Proposed new design
- 50.3.5.1. Partial shroud and suction slot
- 50.3.5.2. External travelling cleaner
- 50.3.5.3. Pressurisation
  
- 51. QUALITY MONITERING
- 51.1. ROTOR YARN USED WITHOUT CLEARING
- 51.2. YARN INSPECTORS FITTED
- 51.3. YARN INSPECTORS ARE EXPENSIVE
- 51.4. APPLICATION OF YARN INSPECTORS
- 51.4.1. Fault replaced with piecing
- 51.4.2. Quality of piecing
- 51.4.3. Automatic piecer
- 51.4.4. Yarn faults affect machine efficiency
- 51.4.5. Low level of faults essential
- 51.5. YARN INSPECTORS ON FRICTION SPINNING MACHINES
- 51.5.1. Lower incidence of faults
- 51.5.2. Yarn inspectors required

SECTION

- 51.6. MEASURED PACKAGE DIAMETER
- 51.7. MEASURED LENGTH
- 51.8. ELECTRONIC DATA COLLECTION
  - 51.8.1. Available on some automated rotor spinners
  - 51.8.2. Specialist suppliers
- 51.9. SPECIAL PROBLEM ON FRICTION YARN
  - 51.9.1. Weak yarn
  - 51.9.2. Weak yarn bulkier
- 51.10. AUTOMATED FRICTION SPINNER
  - 51.10.1. Yarn used directly off machine
  - 51.10.2. Problem in using yarn directly off machine
  - 51.10.3. Proposal to overcome problem
    - 51.10.3.1. Key feature
    - 51.10.3.2. Basic proposal
    - 51.10.3.3. Simplest system
    - 51.10.3.4. Density throughout package build
    - 51.10.3.5. Package diameter recorded on every position
    - 51.10.3.6. Package diameter measured by robot
    - 51.10.3.7. Recommendations
    - 51.10.3.8. Further uses